

Super Quiet Generators

**SUPER QUIET GENERATORS
T50**
Specifications

System Power Output	T50
Prime 3 phase power	39 kW / 49 kVA
Standby 3 phase power	43 kW / 54 kVA
Available 3 phase voltage	208 / 220 / 240 / 440 / 480
Associated 3 phase amps (0.8 power factor)	136 / 129 / 118 / 64 / 59
Prime 1 phase power	32 kW / 32 kVA
Available 1 phase voltage	120 / 240
Associated 1 phase Amps (1.0 power factor)	267 / 134
Max Amp rating (main breaker size)	150 A

Engine

Manufacturer, model	Kubota, V3800DI-T-E3BG
Horsepower - Prime (1800 rpm)	63.7 hp (47.5 kWm)
Description	Vertical 4-cycle Liquid Cooled Diesel
Bore & stroke	3.94 x 4.72 in (100 x 120 mm)
Piston displacement	223 in ³ (3.769 L)
Compression ratio	19:1
Exhaust system	In-line muffler
Monitoring gauges	Oil pressure, water temperature, fuel level, battery voltage, hours
Coolant capacity (engine only)	6.0 qts (5.7 L)
Cooling system	Liquid Cooled - Rated to 120° F Ambient

Super Quiet Generator T50

Specifications

Fuel System		T50
Fuel specification		#2 diesel
Filter		Fuel/water separator
Capacity		75 gal (284 L)
Tank and containment		Internal fuel tank with 110% fluid spill containment
Consumption and run time	- Full Load	3.46 gal/hr (13.1 L/hr) 21 hrs
	- ¾ Load	2.81 gal/hr (10.6 L/hr) 25 hrs
	- Half Load	2.13 gal/hr (8.1 L/hr) 31 hrs

System Controls and Distribution	
Governor	Mechanical (+/- 4%)
Protection (safety shutdowns)	Low oil pressure, high water temperature overcrank, overspeed, underspeed
Generator gauges	Voltmeter, ammeter, dial-type Hertz meter
Receptacles, 120 V	2 Each 20 Amp GFCI Duplex
Receptacles, 240 V	2 Each 50 Amp Tempower T/L
Primary distribution	5 lug terminals with mainline circuit breaker

Generator	
Rating (0.8 power factor)	52 kW 3 phase @ 480/240V
Description	Brushless, 4 Pole, synchronous, single bearing
Insulation	Class H
Temperature rating	125° C rise over 40° C ambient
Automatic voltage regulator	External, solid state, adjustable
Voltage regulation	+/- 1%
Frequency (speed)	60 Hertz (1800 RPM)

Packaging	
Enclosure	Sound attenuated, weatherproof with lockable doors
Sound levels	66 dBA at 23 ft (7 meters) prime load
Lifting system	Roof-mounted, single point
Weight (no trailer)	
- empty	2,749 lb (1,247 kg)
- full	3,197 lb (1,450 kg)
Dimensions - L x W x H (no trailer)	84 x 39 x 51 in (213 x 99 x 130 cm)
Weight (with trailer)	
- empty	3,224 lb (1,463 kg)
- full	3,672 lb (1,666 kg)
Dimensions - L x W x H (with trailer)	137 x 66 x 68 in (348 x 168 x 173 cm)

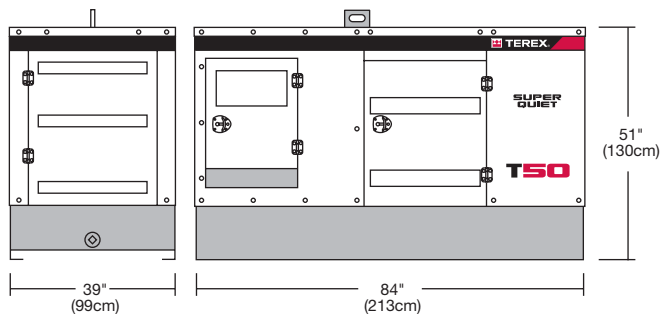

Options and Accessories

Trailer Options
Trailer hitch, 2 in ball
Trailer taillight connector, 4 pole flat
Spare tire (mounts on A frame)
Trailer hitch, 2 5/16 in ball (12,000 lb rated)

Power & Productivity Options
Battery disconnect switch
Electronic governor
5A battery charger with monitoring
Block heater
Cam lock distribution panel, standard lug panel

Lighted control panel
Control panel mounted phase selector switch
External fuel connection
1000 CCA Battery
Automatic air shutdown



Genie Industries, Inc.

A Terex Company

18340 NE 76th Street
PO Box 97030

Redmond, WA 98073-9730

TEL +1 (425) 881-1800

TOLL FREE +1 (800) 536-1800

PARTS & TECH SUPPORT +1 (800) 228-6444

FAX +1 (425) 883-3475

WEB www.genieindustries.com

For more information, product demonstration, or details on purchase, lease and rental plans, please contact your local Genie distributor.

Effective Date: March, 2009. Product specifications and prices are subject to change without notice or obligation. The photographs and/or drawings in this document are for illustrative purposes only. Refer to the appropriate Operator's Manual for instructions on the proper use of this equipment. Failure to follow the appropriate Operator's Manual when using our equipment or to otherwise act irresponsibly may result in serious injury or death. The only warranty applicable to our equipment is the standard written warranty applicable to the particular product and sale and we make no other warranty, express or implied. Products and services listed may be trademarks, service marks or trade-names of Terex Corporation, Genie Industries, Inc. and/or their subsidiaries in the U.S.A. and many other countries. All rights are reserved. Terex® is a registered trademark of Terex Corporation in the U.S.A. and many other countries. Genie® is a registered trademark of Genie Industries, Inc. in the U.S.A. and many other countries. Genie is a Terex Company. © 2009 Terex Corporation.